

> BOX-CA

Unità di filtrazione a carboni attivi

Active carbon filtering units



DESCRIZIONE GENERALE

Le unità BOX-CA sono la soluzione ideale per la filtrazione e la rimozione degli odori. Ideali in ambienti commerciali (bar, ristoranti, etc.) e industriali dove il rumore e gli odori sono un problema. La qualità dell'aria è garantita da una serie di setti filtranti che il fluido deve attraversare prima di uscire dall'unità. La bassa rumorosità è garantita dallo spesso materiale fonoassorbente contenuto all'interno dei pannelli perimetrali (doppio guscio).

COSTRUZIONE

- Telaio in profili d'alluminio e pannelli smontabili (doppio guscio) in lamiera zincata.
- Rivestimento del plenum con tecnopolimero autoestinguente.
- Ventilatore a doppia aspirazione con girante pale avanti accoppiato al motore, mediante cinghie trapezoidali e pulegge di cui la motrice a passo. Ventilatore e motore sostenuti da unico basamento e isolati dalla struttura mediante supporti antivibranti e giunto flessibile sulla mandata.
- Batteria filtrante composta da prefiltro in poliestere a sezione ondulata (classe G3), filtro a tasche morbide (classe F7) e filtro a carbone attivo in cartucce.
- Motore asincrono trifase a norme internazionali IEC 60034, IEC 60072, EMC 2004/108/CE, LVD 2006/95/CE e marcato CE IP55, classe F. Idoneo ad un servizio S1 (funzionamento continuo a carico costante).

GENERAL DESCRIPTION

The BOX-CA units are the ideal solution for air filtering and for smells removal. Ideal for commercial environments (bar, restaurants, etc.) and industrial plants where noise and bad smells are a problem. The quality of the air is granted by a series of filtering sections crossed by the airflow. The low noise level is granted by the thick acoustic insulation of the double skin panels.

CONSTRUCTION

- Frame in extruded aluminium profiles and removable double skin panels in galvanized steel sheet.
- Lining of the plenum with self-extinguishing techno-polymer material.
- Double inlet centrifugal fan with forward curved blades, driven by trapezoidal belts and adjustable pulleys. Fan and motor supported by single base frame and isolated from the main structure by anti-vibration mounts and flexible joint on the outlet.
- Filtering battery composed by wavy polyester pre-filter (class G3), pocket filter (class F7) and activated charcoal filter in cartridges.
- Asynchronous three-phase motors according to international standards IEC 60034, IEC 60072, EMC 2004/108/CE, LVD 2006/95/CE, CE marked, IP 55, class F. Suitable for S1 service (continuous working at constant load).

ORIENTAMENTI Discharge angles

BOX-CA

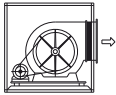
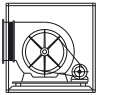
ISPEZIONE INSPECTION DX	Dx-A1 
ISPEZIONE INSPECTION SX	Sx-A1 

N.B: Orientamento standard DX-A1
Standard discharge angles DX-A1



Frequenza 50Hz – Temperatura dell'aria 15°C – Pressione barometrica 760 mm Hg – Peso specifico dell'aria 1,22 Kg/m³
 Frequency 50Hz – Air temperature 15°C – Barometric pressure 760 mm Hg – Air specific weight 1,22 Kg/m³

Lp: livello di pressione sonora rilevato a 1,50 m - **Lp:** sound pressure level measured at 1,50 m

BOX-CA 300 (Q.tà carbone / Q.ty activated carbon: 31 kg)

Tipo Type	Modello Model	U	P	Pm (kW)	In (A)	IP/CL	Mot. (Gr)
BOX-CA	300	T	4	1,10	2,60	55/F	90S

Limiti d'impiego - Operational limit

Tipo Type	Modello Model	Q max (m ³ /h)	PS (mm H2O)	rpm	Lp dB(A)
BOX-CA	300	3000	20	1550	65

BOX-CA 600 (Q.tà carbone / Q.ty activated carbon: 62 kg)

Tipo Type	Modello Model	U	P	Pm (kW)	In (A)	IP/CL	Mot. (Gr)
BOX-CA	600	T	4	2,20	4,80	55/F	100

Limiti d'impiego - Operational limit

Tipo Type	Modello Model	Q max (m ³ /h)	PS (mm H2O)	rpm	Lp dB(A)
BOX-CA	600	6000	25	1080	67

BOX-CA 900 (Q.tà carbone / Q.ty activated carbon: 104 kg)

Tipo Type	Modello Model	U	P	Pm (kW)	In (A)	IP/CL	Mot. (Gr)
BOX-CA	900	T	4	3,00	6,60	55/F	100

Limiti d'impiego - Operational limit

Tipo Type	Modello Model	Q max (m ³ /h)	PS (mm H2O)	rpm	Lp dB(A)
BOX-CA	900	9000	20	880	70

BOX-CA 450 (Q.tà carbone / Q.ty activated carbon: 52 kg)

Tipo Type	Modello Model	U	P	Pm (kW)	In (A)	IP/CL	Mot. (Gr)
BOX-CA	450	T	4	1,50	3,50	55/F	90L

Limiti d'impiego - Operational limit

Tipo Type	Modello Model	Q max (m ³ /h)	PS (mm H2O)	rpm	Lp dB(A)
BOX-CA	450	4500	20	1300	66

BOX-CA 750 (Q.tà carbone / Q.ty activated carbon: 83 kg)

Tipo Type	Modello Model	U	P	Pm (kW)	In (A)	IP/CL	Mot. (Gr)
BOX-CA	750	T	4	3,00	6,60	55/F	100

Limiti d'impiego - Operational limit

Tipo Type	Modello Model	Q max (m ³ /h)	PS (mm H2O)	rpm	Lp dB(A)
BOX-CA	750	7500	25	1140	67

BOX-CA 1200 (Q.tà carbone / Q.ty activated carbon: 124 kg)

Tipo Type	Modello Model	U	P	Pm (kW)	In (A)	IP/CL	Mot. (Gr)
BOX-CA	1200	T	4	4,00	8,30	55/F	112M

Limiti d'impiego - Operational limit

Tipo Type	Modello Model	Q max (m ³ /h)	PS (mm H2O)	rpm	Lp dB(A)
BOX-CA	1200	12000	20	850	72

DIMENSIONI *Dimensions*

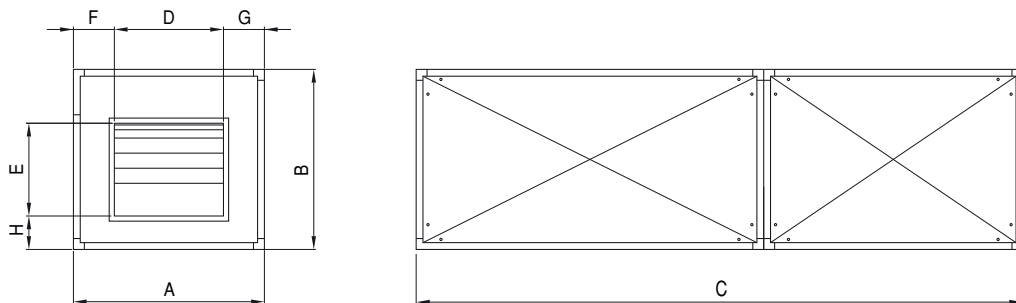

TIPO TYPE	A	B	C	D	E	F	G	H	kg
BOX-CA 300	670	670	2000	330	290	170	170	260	155
BOX-CA 450	1080	750	2100	400	340	340	340	300	200
BOX-CA 600	1280	800	2275	470	400	405	405	320	290
BOX-CA 750	1680	800	2275	470	400	605	605	320	330
BOX-CA 900	1280	1080	2440	560	480	360	360	370	360
BOX-CA 1200	1280	1280	2440	560	480	360	360	370	420

Dimensioni in mm / Dimensions in mm

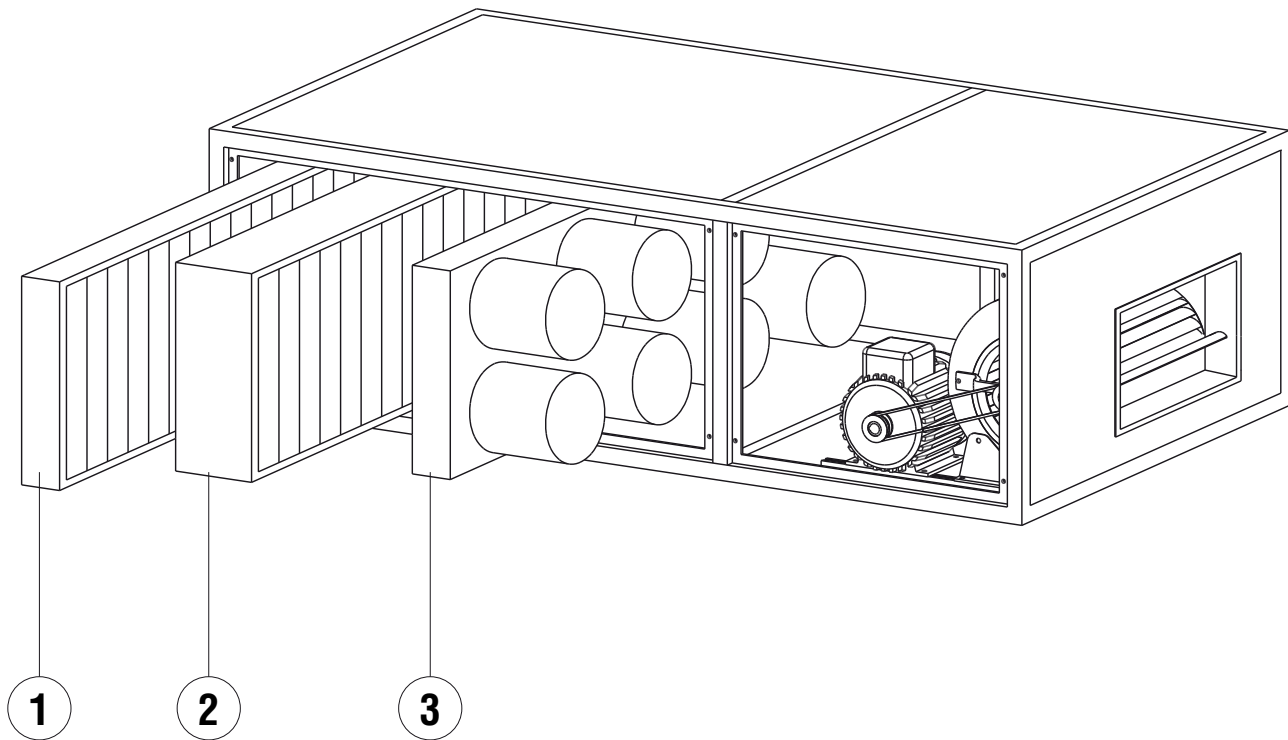

- 1) Prefiltro con setto in poliestere non rigenerabile, a sezione ondulata. Efficienza di separazione ponderale (prova gravimetrica)ASHRAE 52-76 (STD)/EUROVENT 4-5 pari al 84% classe G3. Telaio in lamiera zincata, reti zincate elettrosaldate per il contenimento del setto.
- 2) Filtri a tasche ad alta efficienza, non rigenerabili. Media filtrante in microfibre di vetro in infiammabile classe 2. Efficienza di separazione ponderale (prova gravimetrica) ASHARE 52-76 (STD) / EUROVENT 4-5 pari al 80/85% classe EU7.
- 3) Cartucce contenenti carbone di torba estruso, attivato fisicamente.
 - Densità teorica (sul secco) 470 g/l.
 - Diametro cilindretti 4 mm.
 - Resistenza all'abrasione (ASTM) 97%.
 - Area superficiale interna determinata con il metodo B.E.T. e relativa al benzene 900 mq/g.
 - Temperatura di accensione 450°C.

- 1) *Pre-filter with not reusable section in polyester, with waved section. Efficiency of weighting separation (gravimetric test) ASHRAE52-76 (STD) / EUROVENT 4-5 equal to 84% class G3. Frame in galvanized steel sheet, electro-welded galvanized guards to contain the polyester.*
- 2) *High efficiency pocket filters, not reusable. Filtering in flammable micro-fibres of glass class 2 . Efficiency of weighting separation (gravimetric test) ASHARE 52-76 (STD) / EUROVENT 4-5 equal to 80/85% class EU7.*
- 3) *Cartridges containing activated charcoal, with high absorbing capacity.*
 - *Theoretical density (dry condition) 470 g/l.*
 - *Diameter cylinders 4 mm.*
 - *Abrasion resistance (ASTM) 97%.*
 - *Internal superficial area determined with the B.E.T method. and relative to benzene 900 sq.m./g.*
 - *Ignition temperature of 450°C.*