

> QC

Ventilatori assiali a telaio quadro industriale

Plate mounted axial fans



DESCRIZIONE GENERALE

I ventilatori della serie QC sono adatti per la ventilazione, con fissaggio a parete o su pannelli nelle più svariate applicazioni civili, industriali e commerciali. La serie è costituita da 10 modelli con diametro della girante da 200 a 710 mm. L'impiego della serie QC è previsto con aria pulita nell'intervallo di temperatura da -10°C / $+50^{\circ}\text{C}$. E' disponibile la versione antideflagrante QC-ATX costruita e certificata in conformità alla Direttiva ATEX 94/9 CE ed il suo impiego è previsto con aria pulita -10°C / $+40^{\circ}\text{C}$. Tali serie sono adatte all'installazione in zona 1/21, cioè in aree o ambienti dove sia necessario garantire un elevato fattore di sicurezza contro le esplosioni, dovuti a gas (I12G) e/o polveri infiammabili (I12D/I12GD). Questi apparecchi sono certificati da Ente Notificato secondo la norma 94/9 CE.

Il bocaglio ottimizzato in aspirazione riduce il rumore e aumenta l'efficienza aeraulica.

COSTRUZIONE

- Telaio portante in lamiera d'acciaio stampato e imbutito, con ampio raggio in aspirazione. Verniciato a polveri epossipoliestiriche.
- Girante con pale a profilo alare in nylon-vetro (antistatico per QC-ATX) e mozzo in fusione di lega d'alluminio. Bilanciata secondo ISO 1940.
- Esecuzione 5 (accoppiamento diretto con girante a sbalzo). Flusso dell'aria da motore a girante.
- Rete di protezione, lato motore, in tondino d'acciaio trafilato e verniciato. Realizzata a norme UNI 10615.

MOTORIZZAZIONI

- QC: motore asincrono trifase o monofase a norme internazionali IEC 60034, IEC 60072, EMC 2004/108/CE, LVD 2006/95/CE e marchio CE IP55, classe F.
- QC 200/250: motori a poli schermati, classe B.
- QC-ATX: motore asincrono trifase o monofase I12G, I12D, I12GD a norme internazionali IEC 60034, IEC 60072, IEC 60079 e/o IEC 61241, EMC 2004/108/CE, LVD 2006/95/CE, con certificati ATEX e marcatura CE, IP 55/IP 65, classe F. Tutti idonei ad un servizio S1 (funzionamento continuo a carico costante).

ACCESSORI

- Serranda a gravità (S).
- Distanziatore realizzato in lamiera verniciata a polveri epossipoliestiriche (D).
- Rete di protezione lato girante, realizzata a norme UNI 10615 e protetta contro gli agenti atmosferici (R).

A RICHIESTA

- Girante con pale a profilo alare in lega d'alluminio.
- Flusso dell'aria da girante a motore.

GENERAL DESCRIPTION

The fans of the QC series are suitable for the ventilation, with wall or panel, in residential, commercial and industrial buildings. The series consists of 10 models with impeller diameter from 200 to 700 mm. The use of the QC series is foreseen for clean air in the temperature range -10°C $+50^{\circ}\text{C}$.

The explosion-proof version QC-ATX is certified by a Notified Body according to the 94/9/CE Atex Directive and is suitable to convey clean air in the temperature range -10°C $+40^{\circ}\text{C}$. This version is suitable for installation in zone 1/21, that are areas where it is necessary to guarantee high security against explosions and fires due to presence of flammable gas(I12G) and/or dusts (I12D/I12GD).

The optimized inlet cone reduces noise level and increases the efficiency.

CONSTRUCTION

- Supporting frame in drawn steel sheet, with wide radius inlet cone, epoxy coated.
- Impeller with airfoil blades in glass reinforced polyamide (antistatic version for QC-ATX) and hub in die-cast aluminium alloy, balanced according ISO 1940.
- Execution 5 (direct coupling motor/impeller). Air-flow from motor to impeller.
- Inlet protection guard in steel painted rod, manufactured according to norms UNI 10615 and weatherproof.

MOTORIZATIONS

- QC: asynchronous three-phase or single-phase motors according to international standards IEC 600034, IEC 60072, EMC 2004/108/CE, LVD 2006/95/CE, CE marked, IP 55, class F.
- QC 200/250: fitted with shielded poles motors, class B.
- QC-ATX: asynchronous three-phase motors or single-phase I12G, I12D, I12GD according to international standards IEC 60034, IEC 60072, IEC 60079 and/or IEC61241, EMC 2004/108/CE, LVD 2006/95/CE, with Atex certification, CE marked, IP55/IP 65, class F. All suitable to S1 service (continuous working at constant load).

ACCESSORIES

- Gravity shutter (S).
- Spacer manufactured in epoxy painted steel sheet (D).
- Impeller side protection guard manufactured according to UNI10615 rules and protected against atmospheric agents (R).

UPON REQUEST

Impeller with airfoil blades in die-cast aluminium alloy.
Airflow from impeller to motor.

sez. 3

pag. 2



Frequenza 50Hz – Temperatura dell'aria 15°C – Pressione barometrica 760 mm Hg – Peso specifico dell'aria 1,22 Kg/m³
 Frequency 50Hz – Air temperature 15°C – Barometric pressure 760 mm Hg – Air specific weight 1,22 Kg/m³

Lp: livello di pressione sonora rilevato a 3 m - **Lp**: sound pressure level measured at 3 m

QC 200

Tipo Type	Modello Model	U	P	Pm (kW)	In (A)	IP/CL	Mot. (Gr)	Lp dB(A)
QC	204	M	4	0,03	0,33	20/B	80x80	33
QC	204	T	4	0,03	0,16	44/B	50	32
QC - ATX	204	M	4	0,09	0,50	55/F	56	33
QC - ATX	204	T	4	0,09	0,36	55/F	56	32
QC	202	M	2	0,05	0,36	20/B	50	47
QC	202	T	2	0,05	0,17	44/B	50	47
QC - ATX	202	M	2	0,12	1,20	55/F	56	47
QC - ATX	202	T	2	0,12	0,38	55/F	56	47

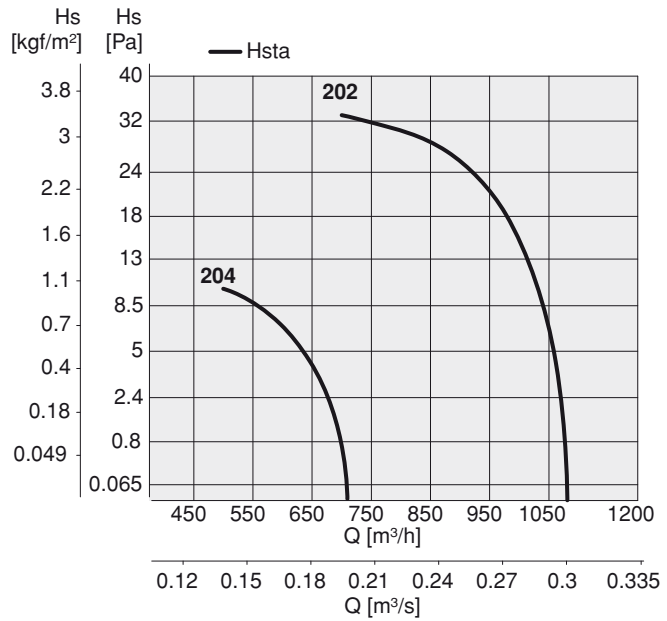

QC 250

Tipo Type	Modello Model	U	P	Pm (kW)	In (A)	IP/CL	Mot. (Gr)	Lp dB(A)
QC	254	M	4	0,07	0,35	44/B	50	39
QC	254	T	4	0,03	0,16	44/B	50	39
QC - ATX	254	M	4	0,09	0,50	55/F	56	39
QC - ATX	254	T	4	0,09	0,36	55/F	56	39
QC	254-30°	M	4	0,07	0,35	44/B	50	36
QC	254-30°	T	4	0,03	0,16	44/B	50	36
QC	252	M	2	0,12	1,10	55/F	56	55
QC	252	T	2	0,12	0,42	55/F	56	55
QC - ATX	252	M	2	0,12	1,20	55/F	56	55
QC - ATX	252	T	2	0,12	0,38	55/F	56	55

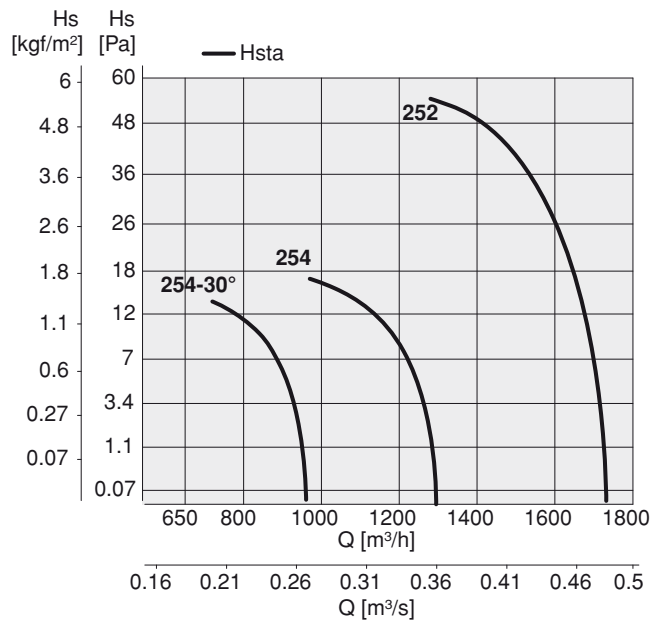

QC 310

Tipo Type	Modello Model	U	P	Pm (kW)	In (A)	IP/CL	Mot. (Gr)	Lp dB(A)
QC	314	M	4	0,09	1,10	55/F	56	48
QC	314	T	4	0,09	0,40	55/F	56	48
QC - ATX	314	M	4	0,09	0,5	55/F	56	48
QC - ATX	314	T	4	0,09	0,36	55/F	56	48
QC	314-30°	M	4	0,07	0,35	44/B	50	45
QC	314-30°	T	4	0,03	0,16	44/B	50	45
QC	312	M	2	0,25	1,85	55/F	63	67
QC	312	T	2	0,25	0,65	55/F	63	67
QC - ATX	312	M	2	0,25	2,2	55/F	63	67
QC - ATX	312	T	2	0,25	0,82	55/F	63	67

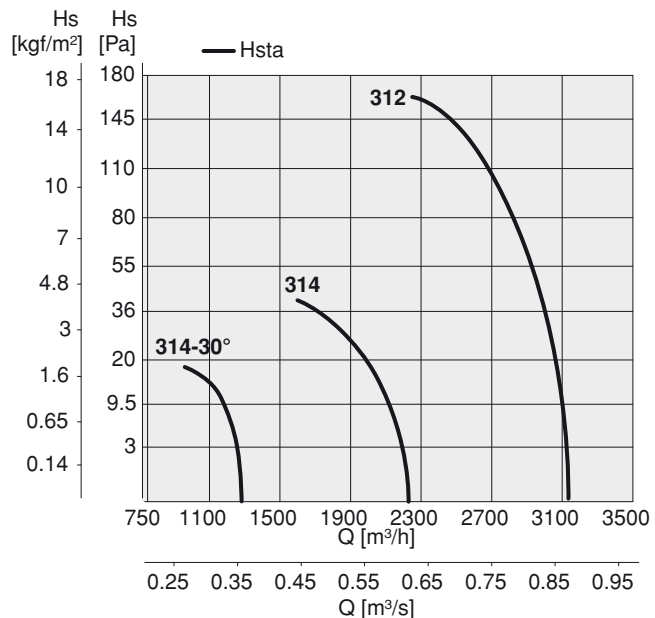



Frequenza 50Hz – Temperatura dell'aria 15°C – Pressione barometrica 760 mm Hg – Peso specifico dell'aria 1,22 Kg/m³
 Frequency 50Hz – Air temperature 15°C – Barometric pressure 760 mm Hg – Air specific weight 1,22 Kg/m³

L_p: livello di pressione sonora rilevato a 3 m - **L_p**: sound pressure level measured at 3 m

QC 350								
Tipo Type	Modello Model	U	P	P _m (kW)	I _n (A)	IP/CL	Mot. (Gr)	L _p dB(A)
QC	354	M	4	0,12	1,10	55/F	63	51
QC	354	T	4	0,12	0,45	55/F	63	51
QC	354-30°	M	4	0,09	1,10	55/F	56	47
QC	354-30°	T	4	0,09	0,40	55/F	56	47
QC - ATX	354	M	4	0,12	1,30	55/F	63	51
QC - ATX	354	T	4	0,12	0,47	55/F	63	51

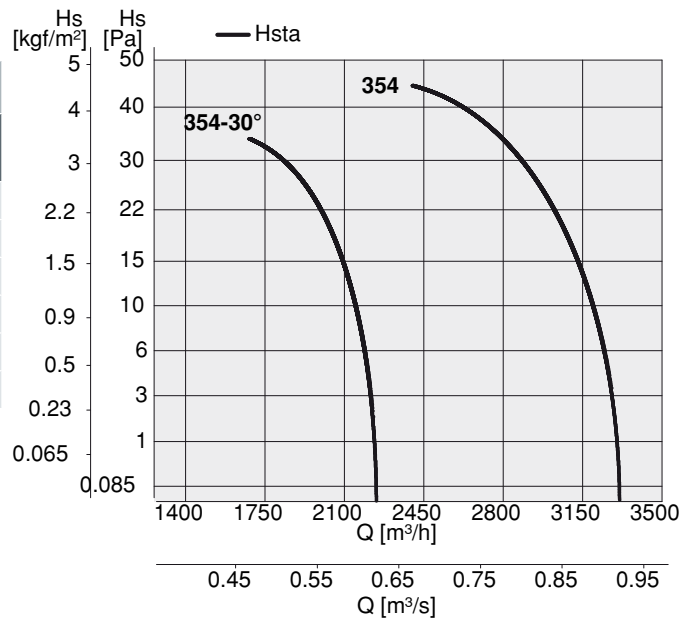

QC 400								
Tipo Type	Modello Model	U	P	P _m (kW)	I _n (A)	IP/CL	Mot. (Gr)	L _p dB(A)
QC	404	M	4	0,18	1,65	55/F	63	55
QC	404	T	4	0,18	0,60	55/F	63	55
QC	404-30°	M	4	0,12	1,10	55/F	63	52
QC	404-30°	T	4	0,12	0,45	55/F	63	51
QC - ATX	404	M	4	0,18	1,70	55/F	63	55
QC - ATX	404	T	4	0,18	0,68	55/F	63	55

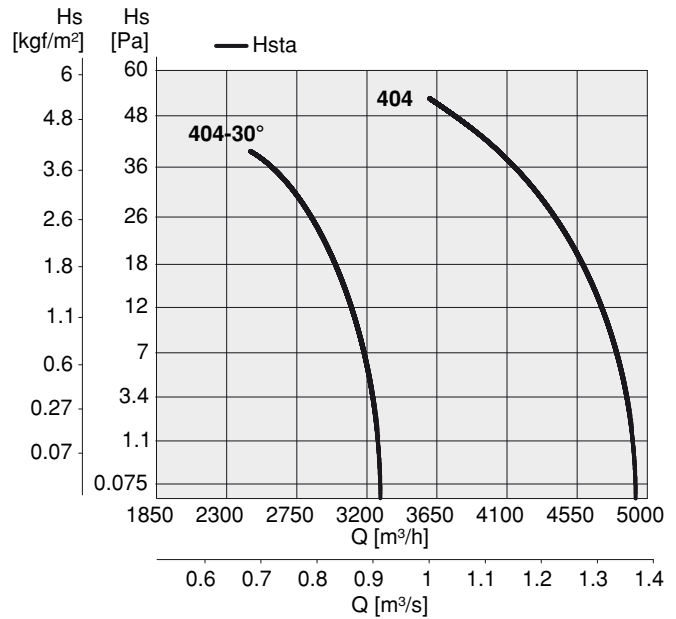

QC 450								
Tipo Type	Modello Model	U	P	P _m (kW)	I _n (A)	IP/CL	Mot. (Gr)	L _p dB(A)
QC	454	M	4	0,37	3,30	55/F	71	61
QC	454	T	4	0,37	1,18	55/F	71	61
QC	454-30°	M	4	0,18	1,65	55/F	63	54
QC	454-30°	T	4	0,18	0,60	55/F	63	54
QC - ATX	454	M	4	0,37	3,1	55/F	80	61
QC - ATX	454	T	4	0,37	1,22	55/F	71	61

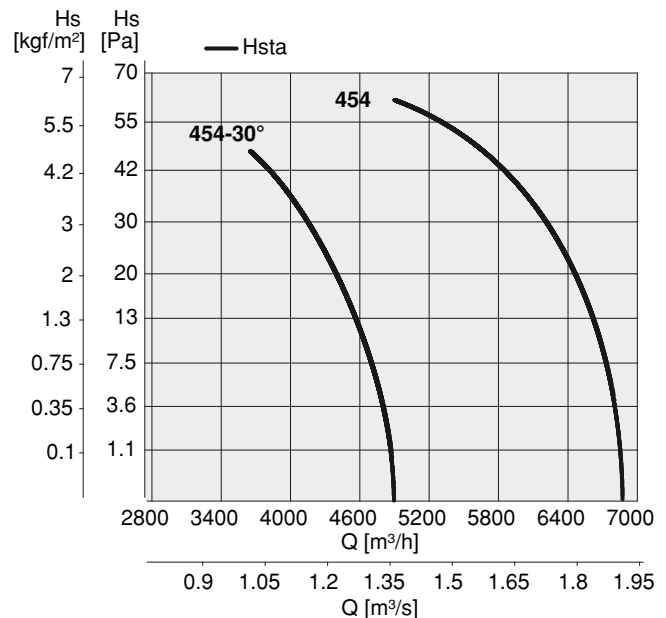



Frequenza 50Hz – Temperatura dell'aria 15°C – Pressione barometrica 760 mm Hg – Peso specifico dell'aria 1,22 Kg/m³
 Frequency 50Hz – Air temperature 15°C – Barometric pressure 760 mm Hg – Air specific weight 1,22 Kg/m³

Lp: livello di pressione sonora rilevato a 3 m - **Lp:** sound pressure level measured at 3 m

QC 500

Tipo Type	Modello Model	U	P	Pm (kW)	In (A)	IP/CL	Mot. (Gr)	Lp dB(A)
QC	504	M	4	0,55	4,40	55/F	80	63
QC	504	T	4	0,55	1,60	55/F	80	63
QC - ATX	504	T	4	0,55	1,75	55/F	80	63
QC	506	M	6	0,18	1,40	55/F	71	53
QC	506	T	6	0,18	0,75	55/F	71	53
QC - ATX	506	T	6	0,18	0,69	55/F	71	53
QC	508	T	8	0,12	0,70	55/F	71	46
QC - ATX	508	T	8	0,09	0,56	55/F	71	46

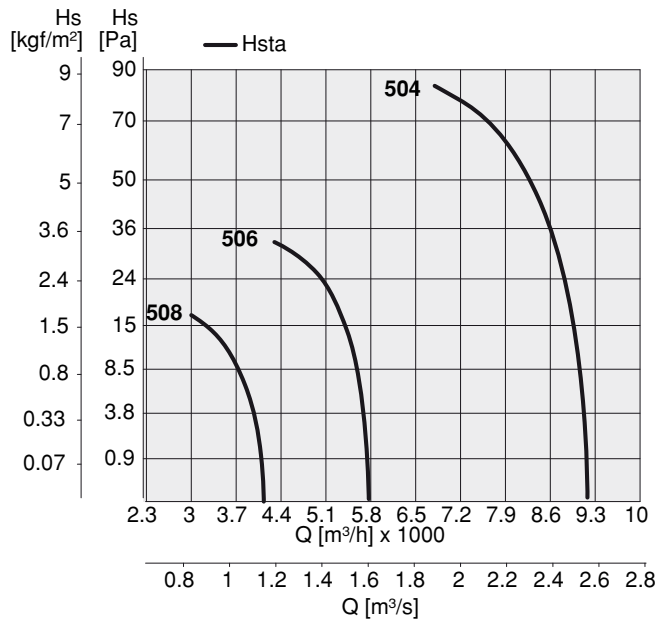

QC 560

Tipo Type	Modello Model	U	P	Pm (kW)	In (A)	IP/CL	Mot. (Gr)	Lp dB(A)
QC	564	T	4	0,75	2,20	55/F	80	67
QC - ATX	564	T	4	0,75	2,11	55/F	80	67
QC	566	T	6	0,26	1,00	55/F	71	55
QC - ATX	566	T	6	0,25	0,89	55/F	71	55
QC	568	T	8	0,12	0,70	55/F	71	48
QC - ATX	568	T	8	0,18	0,87	55/F	80	48

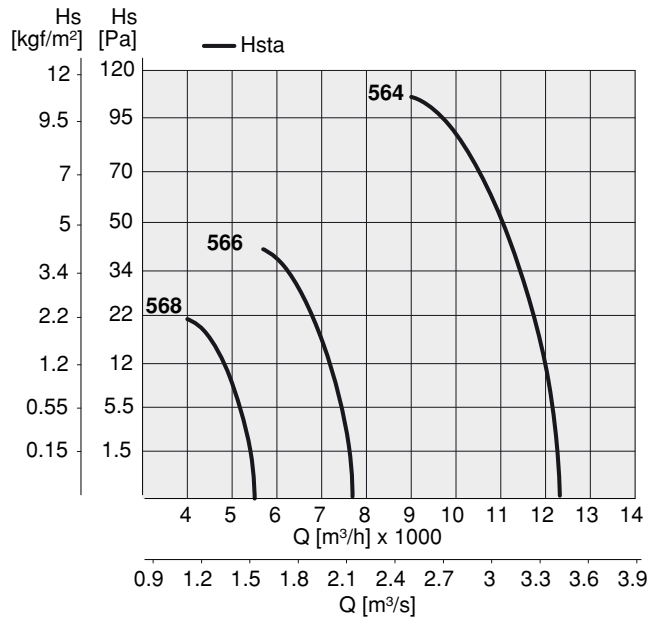

QC 630

Tipo Type	Modello Model	U	P	Pm (kW)	In (A)	IP/CL	Mot. (Gr)	Lp dB(A)
QC	634	T	4	1,10	2,70	55/F	90S	71
QC - ATX	634	T	4	1,10	2,80	55/F	90S	71
QC	636	T	6	0,37	1,20	55/F	80	62
QC - ATX	636	T	6	0,37	1,37	55/F	80	62
QC	638	T	8	0,26	1,10	55/F	80	55
QC - ATX	638	T	8	0,25	1,17	55/F	80	55

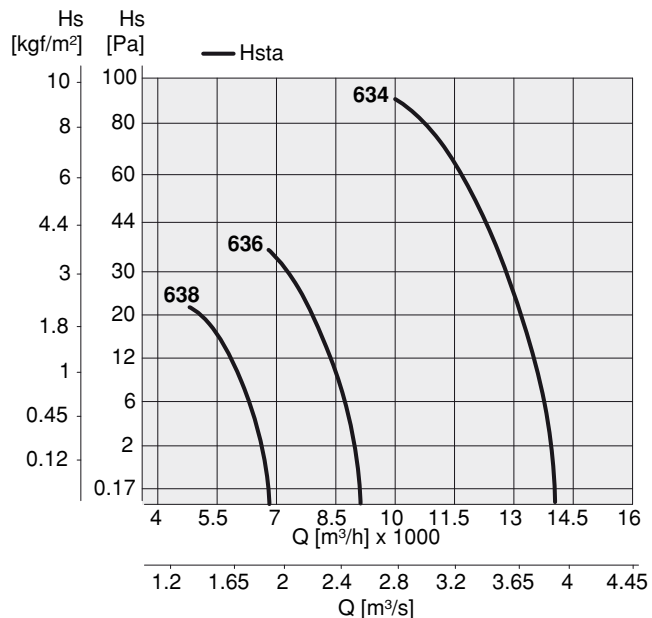



Frequenza 50Hz – Temperatura dell'aria 15°C – Pressione barometrica 760 mm Hg – Peso specifico dell'aria 1,22 Kg/m³
 Frequency 50Hz – Air temperature 15°C – Barometric pressure 760 mm Hg – Air specific weight 1,22 Kg/m³

Lp: livello di pressione sonora rilevato a 3 m - **Lp:** sound pressure level measured at 3 m

QC 710								
Tipo Type	Modello Model	U	P	Pm (kW)	In (A)	IP/CL	Mot. (Gr)	Lp dB(A)
QC	714	T	4	2,20	5,30	55/F	100L	76
QC - ATX	714	T	4	2,20	5,07	55/F	100L	76
QC	716	T	6	0,75	2,40	55/F	90S	65
QC - ATX	716	T	6	0,75	2,23	55/F	90S	65
QC	718	T	8	0,37	1,70	55/F	90S	59
QC - ATX	718	T	8	0,37	1,55	55/F	90S	59

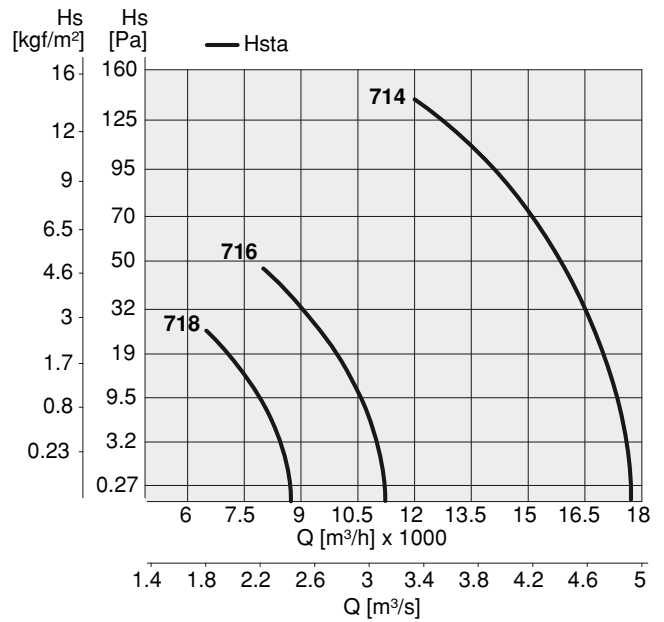

sez. **3**
pag. 6

DIMENSIONI *Dimensions*

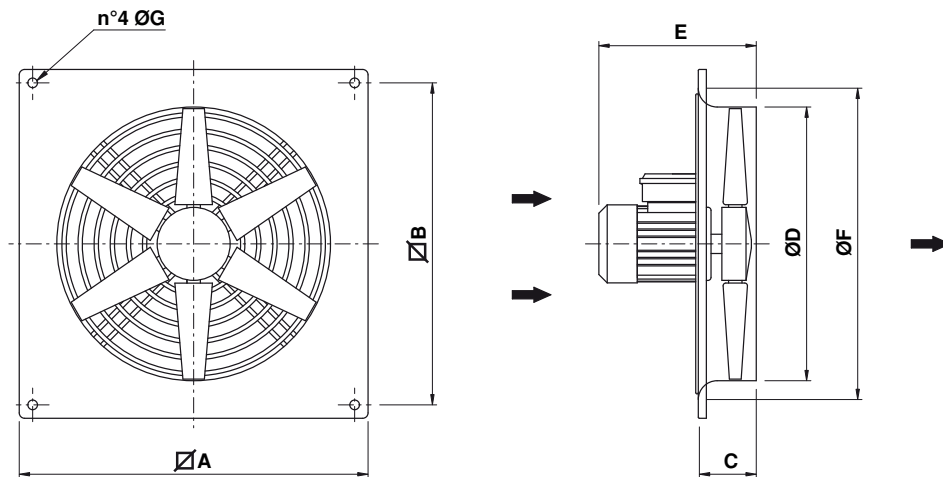

TIPO / TYPE	A	B	C	ØD	E	ØF	ØG	PESO (kg)
QC 200	290	250	88	210	240	260	9	5
QC 250	340	300	88	260	240	315	9	7
QC 300	390	350	88	310	280	365	9	8
QC 350	440	400	108	360	320	410	9	9
QC 400	490	450	108	410	320	465	9	10
QC 450	540	500	108	460	340	510	9	14
QC 500	650	600	108	510	365	570	12	20
QC 560	700	630	108	570	365	630	12	22
QC 630	800	730	108	640	385	700	12	26
QC 710	850	800	108	710	440	770	12	35

Dimensioni in mm / Dimensions in mm

TIPO / TYPE	A	B	C	D	E	F	G	PESO (kg)
QC-EX 200	290	250	88	210	295	260	9	13
QC-EX 250	340	300	88	260	295	315	9	14
QC-EX 300	390	350	88	310	295	365	9	14
QC-EX 350	440	400	108	360	355	410	9	20
QC-EX 400	490	450	108	410	390	465	9	23
QC-EX 450	540	500	108	460	405	510	9	30
QC-EX 500	650	600	108	510	405	570	12	35
QC-EX 560	700	630	108	570	405	630	12	37
QC-EX 630	800	730	108	640	405	700	12	46
QC-EX 710	850	800	108	710	490	770	12	59

Dimensioni in mm / Dimensions in mm